

**Installation,
Operation and
Maintenance
for UL/FM
AWWA
Indicator Post,
Vertical**

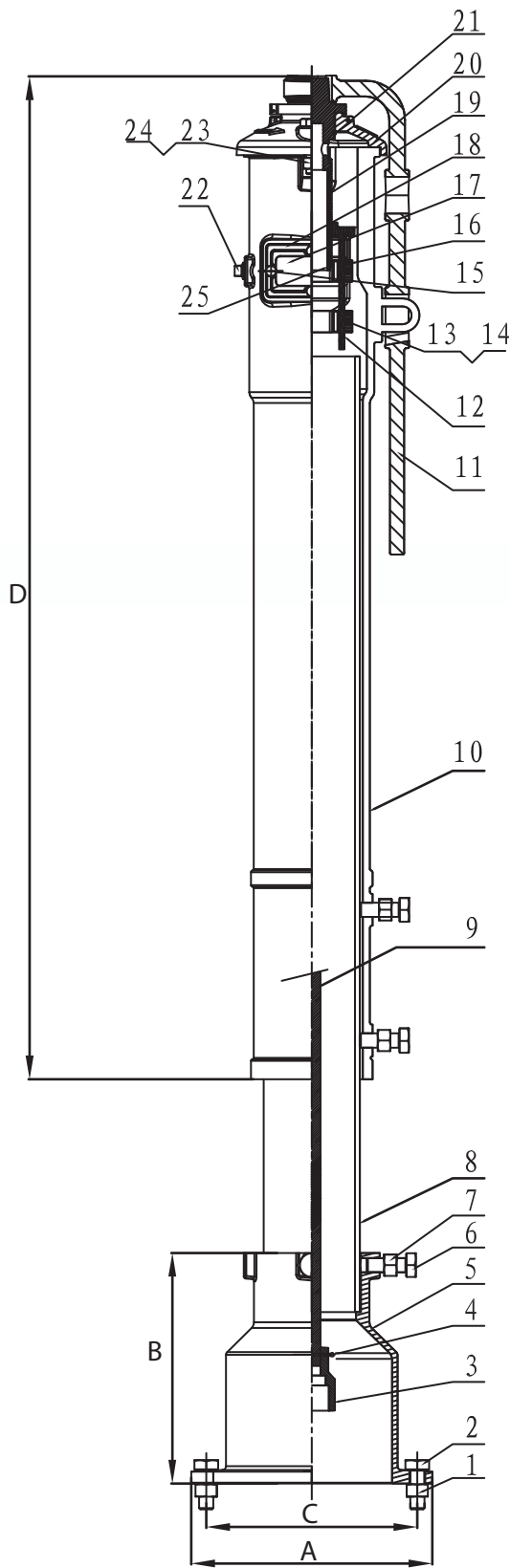



No.	Part	Material
1	Hex Nut	Carbon Steel Zinc Plated
2	Hex Bolt	Carbon Steel Zinc Plated
3	Socket	Ductile Iron Gr. ASTM A536, 65-45-12
4	Cotter Pin	AISI 304 Stainless Steel
5	Base Flange	Cast Iron ASTM A126 Class B
6	Hex Bolt	Carbon Steel Zinc Plated
7	Hex Nut	Carbon Steel Zinc Plated
8	Standpipe	Ductile Iron Gr. ASTM A536, 65-45-12
9	Stem 1" Square	Carbon Steel AISI 1045
10	Body	Cast Iron ASTM A126 Class B
11	Locking Wrench	Carbon Steel Zinc Plated
12	Target Carrier Nut	AISI 304 Stainless Steel
13	Hex Bolt	Carbon Steel Zinc Plated
14	Hex Nut	Carbon Steel Zinc Plated
15	Hex Bolt	Carbon Steel Zinc Plated
16	Open/Shut	Cast Aluminium
17	Window Glass	Plexiglass
18	Gasket	PTFE
19	Operating Nut	AISI 304 Stainless Steel
20	Top Section	Cast Iron ASTM A126 Class B
21	Snap Ring	Stainless Steel AISI1066
22	Plug	Malleable Iron Galvanized
23	Square Nut	Carbon Steel Zinc Plated
24	Hex Bolt	Carbon Steel Zinc Plated
25	Circlip	Carbon Steel Zinc Plated

1) Disassemble the Indicator Post

Remove the Locking Wrench (11) and loosen the two Hex Bolts (24) and Square Nuts (23). Then remove the Top Section (20), Operating Nut (19), Target Carrier Assembly (12+13+14+16), and the Square Stem (9) and Crane Coupling (3).



Remove the Body (10) from the Standpipe (8) by loosening the upper two Hex Bolts (7) and Hex Nuts (6). Then remove the Standpipe (8) from the Base Flange (5) by loosening the lower two Hex Bolts (7) and Hex Nuts (6).

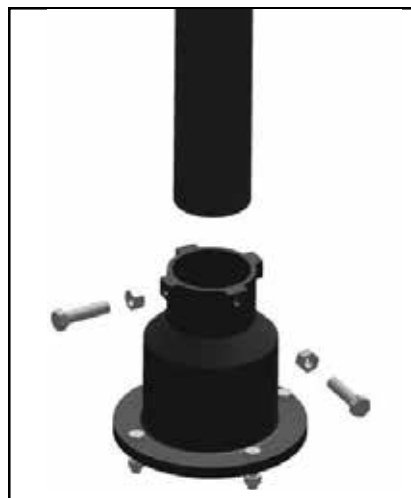

2) Install the Base Flange and Standpipe

Attach the Base Flange (5) to the Post Flange of the Post Indicator Gate Valve using the four Hex Bolts (1) and Hex Nut (2). Then reinsert the Standpipe (8) into the Base Flange (5) and tighten the two Hex Bolts (7) and Hex Nuts (6).



3) Adjust the Ground Line Mark

Lower the Body (10) over the Standpipe (8) until the Ground Line Mark on the Body (10) is the same height as the ground level or finished grade. Tighten the two Hex Bolts (7) and Hex Nut (6).

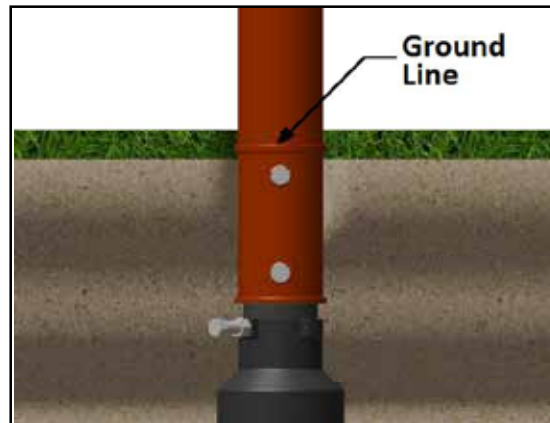

4) Adjust the Square Stem

Lower the Stem (9) into the Body (10) Standpipe (8) so that the Crane Coupling (3) fits over the operating nut of the Post Indicator Gate Valve. Ensure that the Stem (9) engages the Operating Nut of the Vertical Indicator Post (19) a minimum of 2 inches but no more than 4.5 inches. To check for correct engagement, the end of the Stem (9) should be from 2 to 4.5 inches below the top of the Body (10) where it meets the Top Section (20). If the Stem (9) does not fall within this range, then field-cut and deburr the Stem (9) as necessary.

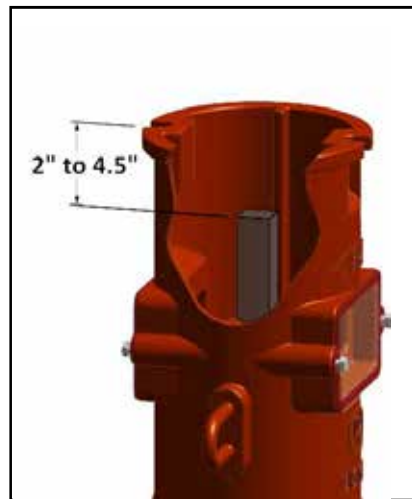
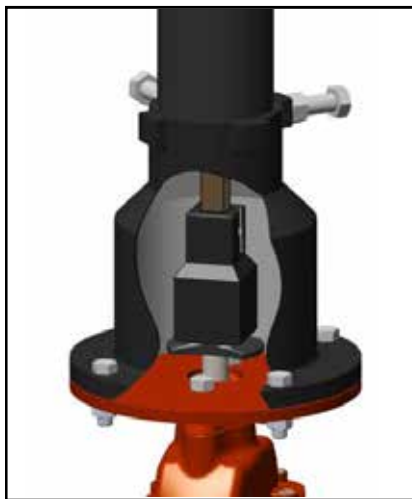

5) Adjust the Targets

The Target Carrier Assembly (12+13+14+16) is adjusted by rotating the Operating Nut (19) with the Target Carrier Assembly held in place. The Open and Shut Targets (16) are adjusted up or down on the Target Carrier Nut (12) by loosening the Target Hex Bolts (13) and Nuts (14), pulling the Target a small distance away from the Target Carrier Nut (12), and sliding the Target up or down as desired. Once the Target is in the correct location, tighten the Hex Bolts (13) and Nuts (14).

If the Non-rising Stem Gate Valve is opened left: Move the two Open Targets (16) to the very top of the Target Carrier Nut (12). Locate the two Shut Targets (16) according to the Non-rising Stem Gate Valve stem size target distance below ("X").

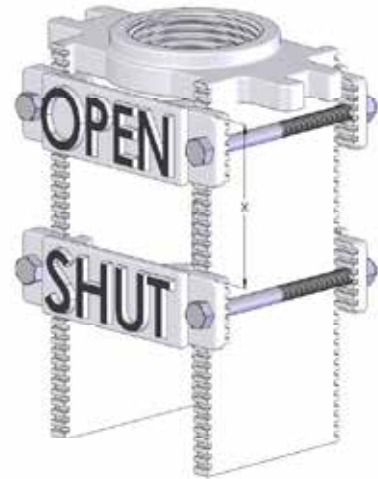

If the Non-rising Stem Gate Valve is opened right: Move the two Shut Targets (16) to the very top of the Target Carrier Nut (12). Locate the two Open Targets (16) according to the Non-rising Stem Gate Valve stem size target distance below ("X").

Approximate* 4"~12" NRS Gate Valve Target Distances (X):

- 4" = 1 $\frac{1}{16}$ " [27 mm]
- 6" = 1 $\frac{5}{8}$ " [41 mm]
- 8" = 2 $\frac{1}{8}$ " [54 mm]
- 10" = 2 $\frac{5}{8}$ " [67 mm]
- 12" = 3 $\frac{1}{8}$ " [79 mm]

* Field adjust as necessary

6) Final Assembly and Test

Reinsert the Top Section (20), Operating Nut (19), and Target Carrier Assembly (12+13+14+16) into the Body (10) until the bottom of the Top Section (20) rests flush with the top of the Body (10). Check to ensure the Open Target (16) is centered within the Target Window Glass (17). If the Open Target (16) is not centered, then remove, adjust, and reinsert the assembly until it is centered within the Target Window Glass (17). This centering of the Open Target (16) should correspond with the Post Indicator Gate Valve being in the open position. Ensure that the Stem (9) engages with the Operating Nut (19) at least 2 inches but no more than 4.5 inches. Secure the Top Section (20) to the Body (10) by tightening the Hex Bolts (24) and Square Nuts (23). Close the Post Indicator Gate Valve, and make sure that the Shut Target is properly centered in the window of the Body (10), adjusting as necessary.



MAINTENANCE:

Oil the bearing in the Top Section (20) at least once a year by adding several drops of oil in the hole located on the top of the Operating Nut (19).